

REBAR PLACEMENT

- #4 @ 10" C/C EA. WAY WALLS
- #4 @ 10" C/C EA. WAY TOP SLAB
- #4 @ 10" C/C EA. WAY BOT SLAB

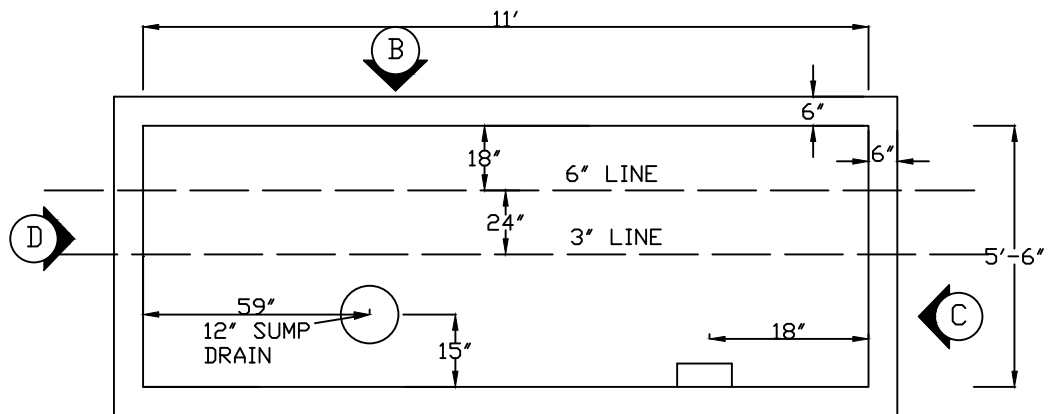
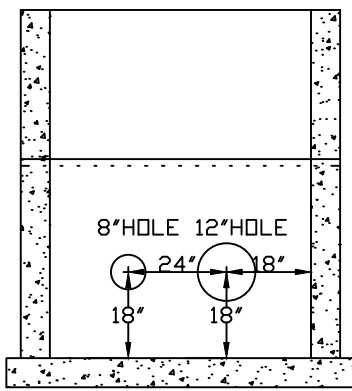
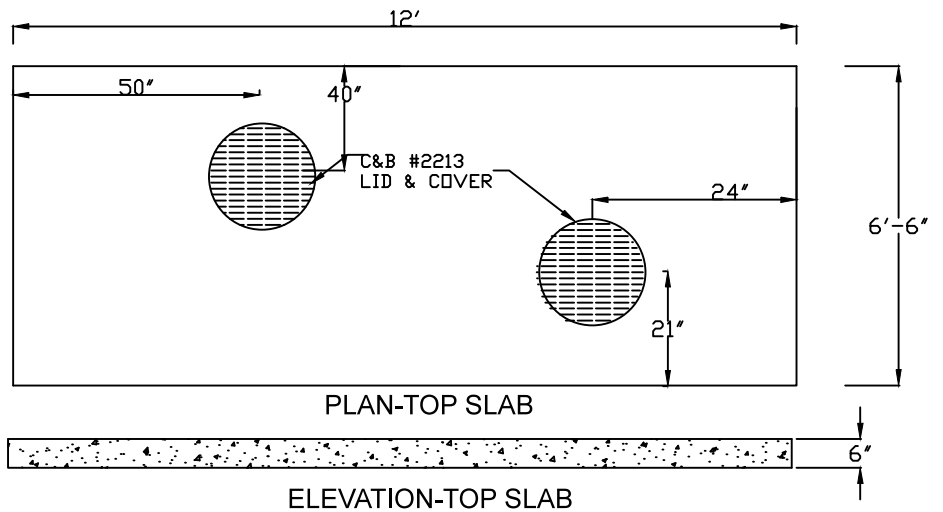

ELEVATION

PLAN-STRUCTURE

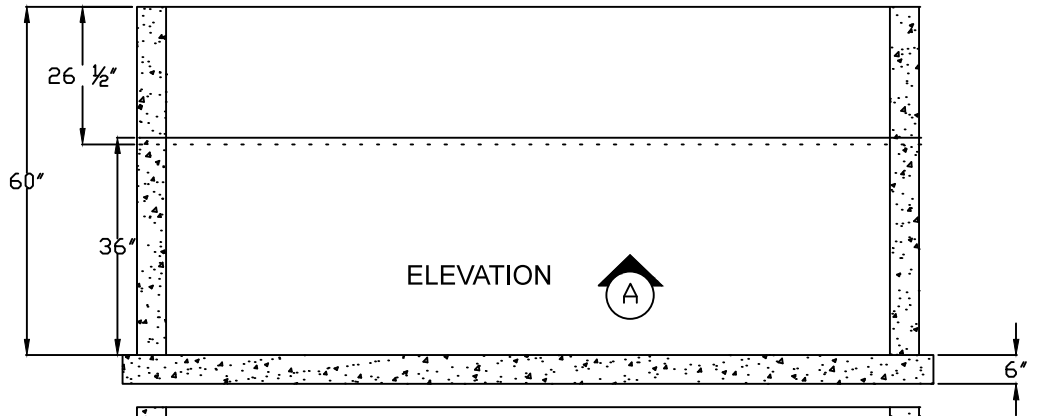
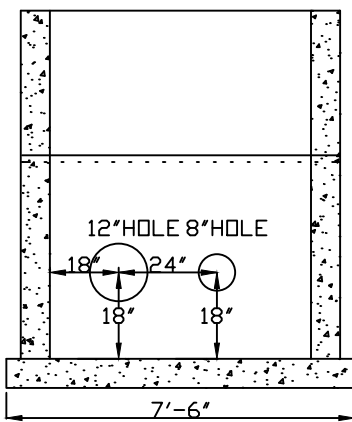

ELEVATION

ELEVATION

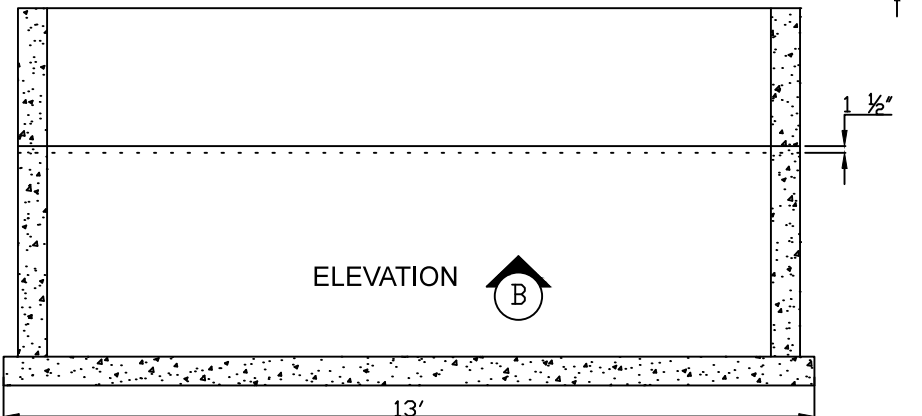

ELEVATION

WT. TOP SLAB 5850#  
 WT. BOT. SECT.WBASE 15178#  
 WT. TOP SECT 5460#